

6-PLATE COUPLING TOTAL THICKNESS 7.2 HUB SECURING BOLTS TO BE TIGHTENED TO A TORQUE OF 84kgf m 822N m

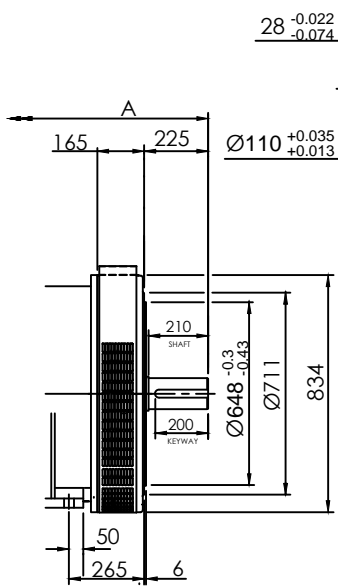

SMF400B-F

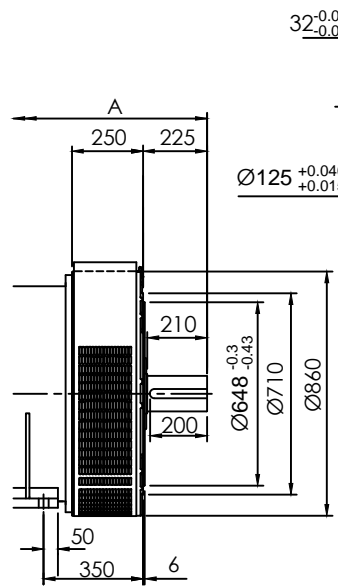

SMF400G/J

"X"-HOLES "Y" DIA EQUI-SPACED ON "P" PCD

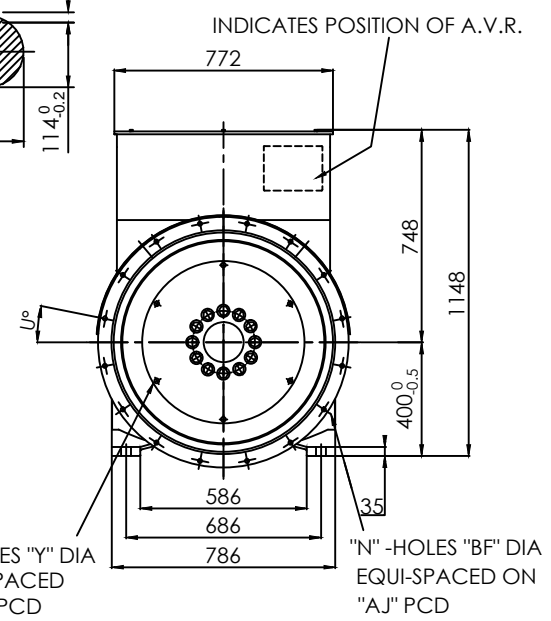

| DIMENSIONS(mm) | | Weight | 2-BRG | |
|----------------|------|--------|-------|------|
| TYPE | LB | Xg | kg | A |
| SMF400B | 1578 | 578 | 1734 | 1718 |
| SMF400C | 1578 | 591 | 1784 | 1718 |
| SMF400D | 1578 | 597 | 1919 | 1718 |
| SMF400E | 1578 | 607 | 2011 | 1718 |
| SMF400F | 1578 | 625 | 2200 | 1718 |
| SMF400G | 1679 | 735 | 2397 | 1904 |
| SMF400J | 1679 | 745 | 2525 | 1904 |

| COUPLING DISC | | | | | |
|---------------|--------|--------|----|------|------|
| SAE | BX | P | X | Y | AH |
| 24 | 733.42 | 692.15 | 12 | 20.7 | 0 |
| 21 | 673.10 | 641.35 | 12 | 16.7 | 0 |
| 18 | 571.50 | 542.92 | 6 | 16.7 | 15.7 |
| 14 | 466.72 | 438.15 | 8 | 13.5 | 25.4 |

| FLANGE mm | | | | | | | |
|-----------|-----|--------|--------|-------|----|----|--|
| SAE | BD | AK | AJ | Uº | BF | N | |
| SAE1 | 835 | 511.18 | 530.22 | 15 | 14 | 12 | |
| SAE1/2 | 835 | 584.20 | 619.12 | 15 | 14 | 12 | |
| SAE0 | 835 | 647.70 | 679.45 | 11.25 | 14 | 16 | |
| SAE00 | 883 | 787.40 | 850.90 | 11.25 | 14 | 16 | |

| | | | | | | |
|--------|-----|------|---------|------------|-----|---------|
| | | | | SMF400 | 1:1 | 7008011 |
| | | | | SAE: | A2 | |
| VER | MOD | DRW | Date | | | SINOCOX |
| Design | | APP | | | | |
| CHK | | Date | 2018.11 | GB/T1804-m | mm | |