

SMF

SINCOX

FUJIAN SINOCOX GENERATOR TECHNOLOGY CO., LTD.

ALTERNATOR

SMF400 Range

_ Rev.H _

APPLICATION AND STANDARDS

Widly used for homes, small shops and offices as a prime power supply or backup

Comply with standards of IEC60034,NEMA MG1-22,IS08528,CSA C22.2-100, VDE 0530, GB755

ELECTRICAL FEATURES

The high efficiency semiconductors of the AVR ensure positive build-up from initial low levels of residual voltage.

6 leads, achieve a variety of voltage output

High efficiency and strong motor start ability

Be capable of running at overload up to 10% for 1 hour every 12 hours.

The "ARAP" - Auxiliary Regulation Adopted Principle is optional

Variety of excitation and voltage regulation system to meet different loads.

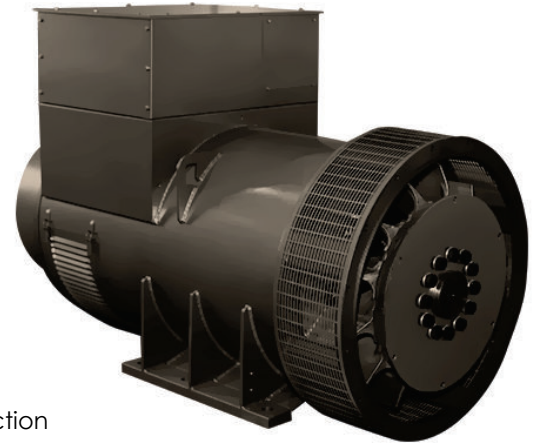

MECHANICAL FEATURES

Be protected to IP23, and IP44 is optional

Sealed for life bearings

Both single bearing and double bearing configurations are available

Steel sheet terminal box, which provides enough space for customer's reconnection

The rotor is dynamically balanced according to ISO 1940. A half-key balanced for double bearings.

INSULATION AND IMPREGNATION

H class insulation

The VPI (Vacuum Pressure Impregnation) equipped to ensure the electrical insulation and mechanical strength.

The "Anti-Harsh" winding is optional to meet the needs of harsh environment

COMMON DATA

INSULATION	ALTITUDE	OVERSPEED	PROTECTION	LEADS	PITCH	AVR	VOLTAGE REGULATION	WAVEFORM DISTORTION	TIF	THF
H/H	<=1000m	2250 rpm	IP23	6	2/3	MX341	± 1%	<1.5% NO LOAD	<50	<2%

RATING TABLE

H CLASS	50Hz/1500RPM/PF 0.8											60Hz/1800RPM/PF 0.8											
	125°C/40°C PRIME POWER										163°C/27°C Standby	Effi.	125°C/40°C PRIME POWER										163°C/27°C Standby
STAR	380	400	415	440	400	400	416	440	460	480	480	480											
DELTA	220	230	240	254	230	230	240	254	266	277	277	277											
RATING	kVA	kW	kVA	kW	kVA	kW	kVA	kW	kVA	kW	%	kVA	kW	kVA	kW	kVA	kW	kVA	kW	kVA	kW	%	
SMF400B	710	568	750	600	750	600	685	548	792	634	94.4	810	648	855	684	895	716	938	750	980	784	94.8	
SMF400C	765	612	800	640	800	640	730	584	840	672	94.6	865	692	916	733	958	766	1000	800	1045	836	94.9	
SMF400D	875	700	915	732	915	732	830	664	958	766	94.6	986	789	1043	834	1090	872	1138	910	1190	952	94.8	
SMF400E	960	768	1020	816	1020	816	920	736	1055	844	95.0	1083	866	1145	916	1197	958	1250	1000	1305	1044	95.2	
SMF400F	1100	880	1138	910	1138	910	1050	840	1200	960	95.2	1204	963	1274	1019	1332	1066	1390	1112	1450	1160	95.5	
SMF400G	1200	960	1250	1000	1250	1000	1150	920	1320	1056	95.4	1310	1048	1386	1109	1449	1159	1513	1210	1580	1264	95.7	
SMF400J	1325	1060	1375	1100	1375	1100	1265	1012	1444	1155	95.5	1419	1135	1488	1190	1550	1240	1625	1300	1694	1355	95.7	

REACTANCE-TIME CONSTANT(s) H CLASS
SMF400 B/C/D/E/F/G/J

60Hz @ 480V		SMF400B	SMF400C	SMF400D	SMF400E	SMF400F	SMF400G	SMF400J
Xd	Direct axis synchro. reactance unsaturated	3.35	2.96	2.92	2.92	2.8	2.14	2.049
X'd	Direct axis transient reactance saturated	0.16	0.15	0.15	0.15	0.14	0.13	0.012
X''d	Direct axis sub transient reactance saturated	0.12	0.1	0.1	0.1	0.09	0.09	0.080
Xq	Quadra. Axis synchro. reactance unsaturated	2.65	2.41	2.33	2.33	2.23	1.82	1.700
X''q	Quadra. Axis sub transient reactance saturated	0.29	0.26	0.28	0.28	0.26	0.23	0.220
X2	Negative sequence reactance unsaturated	0.2	0.199	0.19	0.19	0.18	0.16	0.160
Xo	Zero sequence reactance unsaturated	0.09	0.08	0.08	0.08	0.08	0.03	0.020
Td	Short-Circuit transient time constant	0.08s	0.08s	0.08s	0.08s	0.08s	0.116s	0.115s
T''d	Sub transient time constant	0.012s	0.012s	0.012s	0.012s	0.012s	0.016s	0.015s
Tdo	Open circuit time constant	2s	2.2s	2.5s	2.5s	2.5s	3.61s	3.6s
Ta	Armature time constant	0.017s	0.018s	0.019s	0.019s	0.019s	0.039s	0.038s
Kcc	Short circuit ratio	0.298	0.338	0.342	0.342	0.357	0.467	0.488

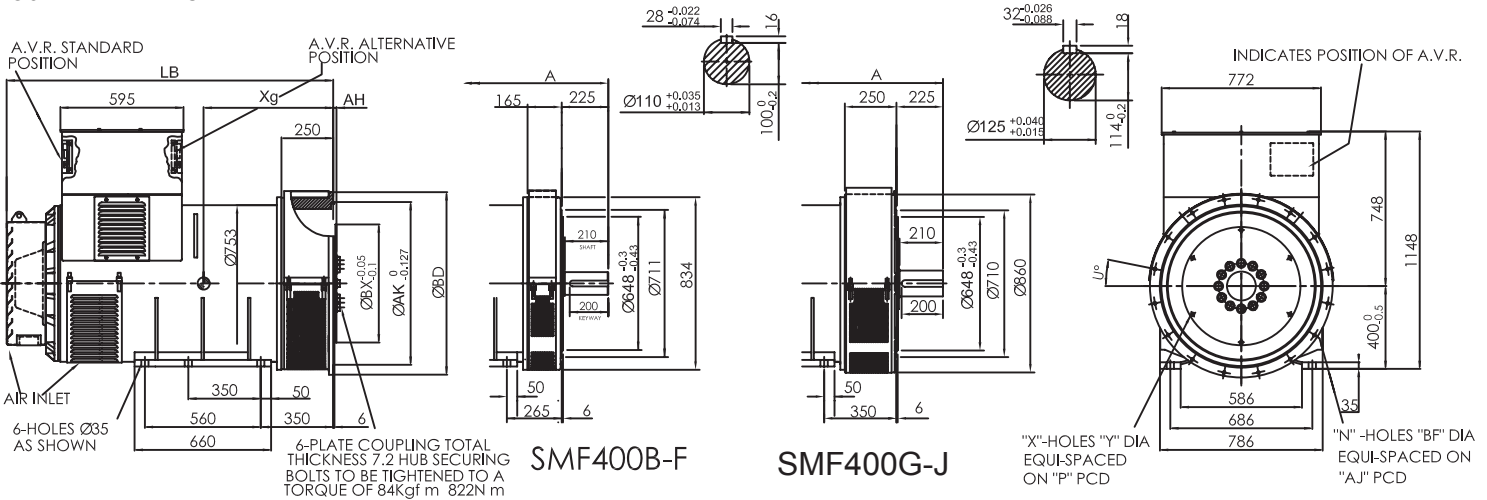
OUTLINE DRAWING

DATA TABLE-DOUBLE BEARING

Dimension (mm)	Double BRG	Weight		Packing
		Net(kg)	Gross(kg)	L x W x H (mm)
Model	A			
SMF400B	1718	1749	1809	1850×1000×1320
SMF400C	1718	1799	1859	1850×1000×1320
SMF400D	1718	1934	1994	1850×1000×1320
SMF400E	1718	2026	2086	1850×1000×1320
SMF400F	1718	2215	2275	1850×1000×1320
SMF400G	1904	2417	2477	2000×1000×1320
SMF400J	1904	2545	2605	2000×1000×1320

DATA TABLE-SINGLE BEARING

Dimension (mm)	SAE 00/0/0.5/1		Weight		Packing
	LB	Xg	Net(kg)	Gross(kg)	L x W x H (mm)
Model					
SMF400B	1578	578	1734	1789	1750×1000×1320
SMF400C	1578	591	1784	1839	1750×1000×1320
SMF400D	1578	597	1919	1974	1750×1000×1320
SMF400E	1578	607	2011	2066	1750×1000×1320
SMF400F	1578	625	2200	2255	1750×1000×1320
SMF400G	1679	735	2397	2452	1850×1000×1320
SMF400J	1679	750	2525	2580	1850×1000×1320

Flange (mm)							Disc(mm)					
SAE#	BD	AK	AJ	BF	N	U°	SAE#	BX	P	X	Y	AH
SAE 1	810	511.18	530.22	14	12	15	24	733.42	692.15	12	20.7	0
SAE 0.5	810	584.20	619.12	14	12	15	21	673.10	641.35	12	16.7	0
SAE 0	810	647.70	679.70	14	16	11.25	18	571.50	542.92	6	16.7	15.7
SAE 00	883	787.40	850.90	14	16	11.25	14	466.72	438.15	8	13.5	25.4